

Level Measurement Expert

Level Measurement Guided Wave Radar

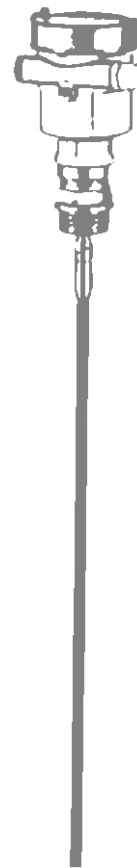
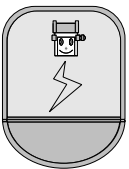
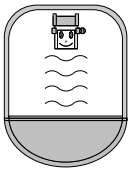
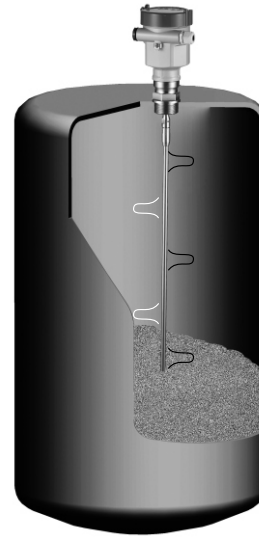

Table of Contents

1	Measurement Principle.	1
2	Product Overview.	2
3	Mounting Requirement.	5
4	Electrical Connection.	7
5	Adjustment Instructions.	10
6	Dimensional Drawings.	13
7	Technical Specifications.	17
8	Selection & Ordering Information.	20
9	Application Questionnaire.	26

1. Measurement Principle



- Principle

High frequency microwave pulses travels along the detecting component (steel rope or rod) and reflects when veaching the product surface. The time from emission to reception is proportional to the distance between the surface and the reference plane on the instrument.

- Features

FDGW5X equipped with the advanced microprocessor and unique EchoDiscovery echo processing technology can be used in severe ambience.

FDGW5X with extremely low emission power, can be mounted on various metal or nonmetal vessels, harmless towards the environment and human beings.

There are multiple options availabe in choosing various process connection and detecting component, which enables **FDGW5X** to be applied in a broad extent of applications, such as high temperature, high pressure, medium with small dielectric constant and etc.

2 Product Overview

FDGW51



FDGW52



Application:	Level measurement for liquids/solids, in severe ambience
Max. Measurement Range:	Rope: 30m/Rod: 6m
Measurement Accuracy:	$\pm 10\text{mm}$
Process Connection:	G1½A、G2A、1½NPT
Detection Component	
Material:	Stainless Steel 316L/PTFE
Process Pressure:	(-0.1~4) MPa
Process Temperature:	(-40~150) °C
Signal Output:	(4~20)mA/HART
Power:	2-Wire (DC24V) 4-Wire (DC24V/AC220V)

Application:	Level measurement for liquids/solids, in severe ambience
Max. Measurement Range:	6m
Measurement Accuracy:	$\pm 10\text{mm}$
Process Connection:	PTFE flange
Detection Component	
Material:	PTFE
Process Pressure:	(-0.1~1.6) MPa
Process Temperature:	(-40~150) °C
Signal Output:	(4~20)mA/HART
Power:	2-Wire (DC24V) 2-Wire (DC24V/AC220V)

FDGW53



FDGW54



Application:	Level measurement for liquids, especially for ones with small dielectric constant, in severe ambience
Max. Measurement Range:	6m
Measurement Accuracy:	± 10mm
Process Connection:	G1½A、G2A
Detection Component	
Material:	Stainless Steel 316L/PTFE
Process Pressure:	(-0.1~4) MPa
Process Temperature:	(-40~150) °C
Signal Output:	(4~20)mA/HART
Power:	2-wire (DC24V) 4-wire (DC24V/AC220V)

Application:	Level measurement for liquids in severe ambience with high temperature/pressure
Max. Measurement Range:	Rope:30m/Rod:6m
Measurement Accuracy:	± 10mm
Process Connection:	G1½A/G2A/1½NPT
Detection Component	Stainless Steel 316L/Chinaaware
Material:	
Process Pressure:	(-0.1~4) MPa
Process Temperature:	(-40~200) °C
Signal Output:	(4~20)mA/HART
Power:	2-wire (DC24V) 4-wire (DC24V/AC220V)

FDGW55



FDGW56



Application:	Level measurement for liquids, especially in severe ambience with very high temperature and pressure
Max. Measurement Range:	Rope: 30m/Rod: 6m
Measurement Accuracy:	± 10mm
Process Connection:	G1½A/G2A/1½NPT
Detection Component Material:	Stainless Steel 316L/Chinaware
Process Pressure:	(Vacuum ~ 40) MPa
Process Temperature:	(-200 ~ 400) °C
Signal Output:	(4 ~ 20) mA/HART
Power:	2-Wire (DC24V) 4-Wire (DC24V/AC220V)

Application:	Level measurement for liquids with small dielectric constant or powder
Max. Measurement Range:	Rope: 30m/Rod: 6m
Measurement Accuracy:	± 10mm
Process Connection:	G1½A/G2A/1½NPT
Detection Component Material:	Stainless Steel 316L/PTFE
Process Pressure:	(-0.1 ~ 4) MPa
Process Temperature:	(-40 ~ 150) °C
Signal Output:	(4 ~ 20) mA/HART
Power:	2-Wire (DC24V) 4-Wire (DC24V/AC220V)

3. Mounting Requirement

- Basic Requirement

Keep in mind that the rope/rod is kept away from obstructions within vessel. The obstructions are like : ladders, limit switches, heating spirals, struts and etc. Furthermore, rope or rods must not intersect the filling streams.

Be cautious during the installation: the level of the measured medium must not be in the blanking zone, the mounting location must keep a min distance to the vessel wall, the rope or rod is perpendicular to the surface of the measured medium. Local or federal safety instruction must be abided when installation is in explosion hazardous area. Aluminium housing is used for intrinsically safe version, which can be used in explosion hazardous areas. The instrument must be connected to ground potential in this situation.

- Illustrations

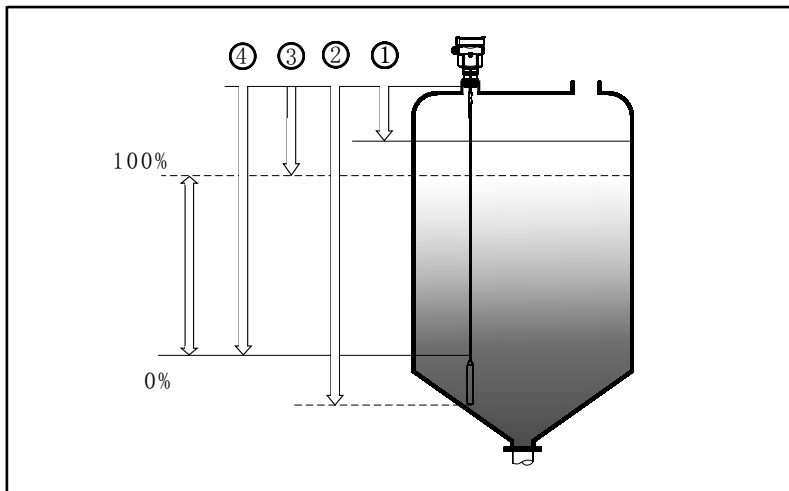

The reference plane is the thread or flange surface

- 1 Blanking Zone (Menu 1. 10)
- 2 Length (Menu1. 9)
- 3 Max. Measurement Range (Menu1. 2)
- 4 Blanking Zone (Menu 1. 1)
- 5 reference plane

Note: The level of the measured medium must not be in either blanking zone.

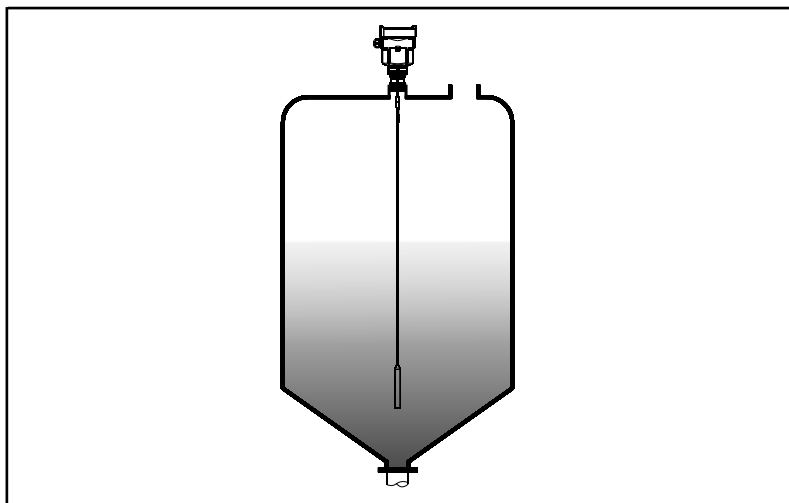

The best mounting location for a conical vessel with flat top is the center of the vessel's top, as the effective measurement can reach the bottom of vessel.

- Socket

Container Extension

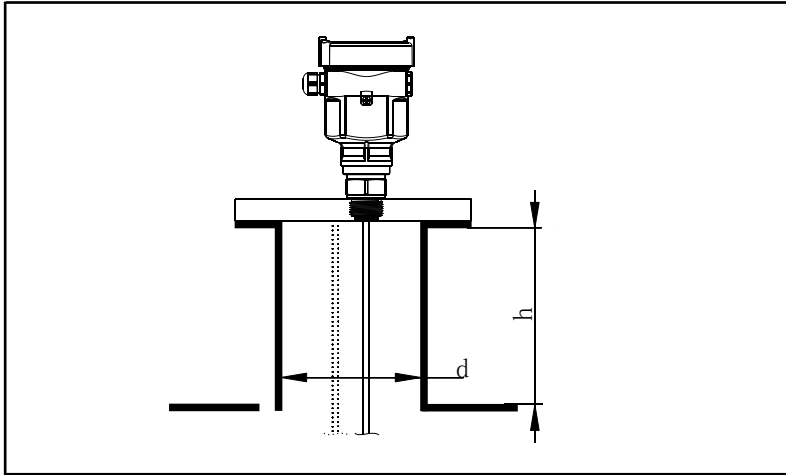

Avoid installation with socket if possible, otherwise try to minimize the length of socket. In case of long socket, small vessel or medium with low dielectric constant, you are advised to use **FDGW56**

- Rights and Wrongs in Mounting

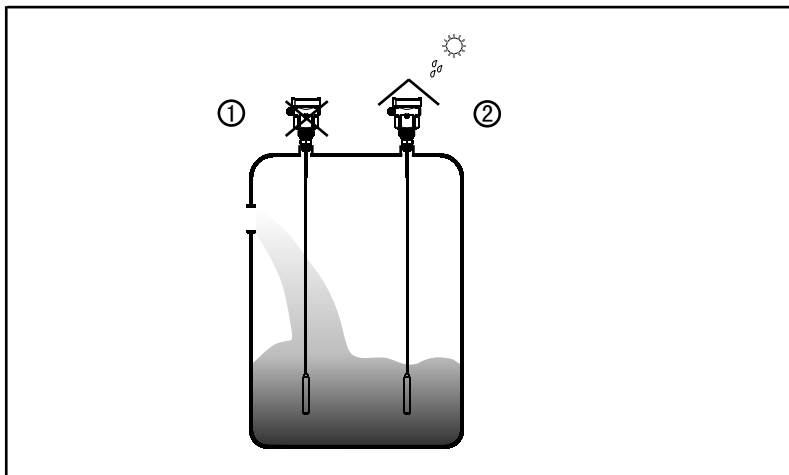

1 Wrong: The rod/rope is in/above filling stream, which results in the measurement of filling stream not the target medium.
 2 Correct
 Note: Sun shield or rain-proof is required for outdoor mounting.

- Damp-proof

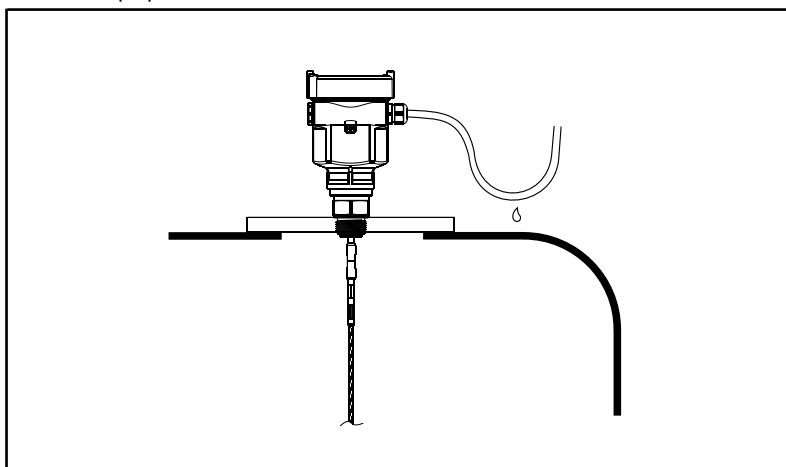

When mounting outdoors, humid indoors or on cooling/heating vessels, in order to avoid damp seal rings used on cables should be screwed tight, and the cable must be bended downward outside cable entry, as indicated on the diagram below:

4 Electrical Connection

- Power Supply

20mA/HART(2-Wire) Power supply and current signal are carried by the same two-wire connection cable. See the Technical Specifications of this guide for detailed requirement on power supply. A safety barrier should be placed between power supply and instrument for intrinsically safe version.

20mA/HART(4-wire) Power supply and current signal are carried by two 2-wire connection cables respectively. See the Technical Specifications of this guide for detailed requirement on power supply. Earth-connected current output can be used for standard version of level instruments, while the explosion proof version must be operated with a floating current output. Both instruments and earth terminals should be connected with ground firmly and securely. Normally you can either choose to connect with the earth terminal on vessel or adjacent ground in case of plastic vessels.

- Cable Connection

General Introduction

4~20mA/HART Standard 2-wire cable with outside diameter of 5...9mm, which assures the seal effect of cable entry, can be used as feeder cable. You are recommended to use screened cables in the event of electromagnetic Connection cable with special earth wire can be used as feeder cable.

Connection cable with special earth wire can be used as feeder cable.

20mA/HART(4-wire)

Shielding & Grounding The two ends of shielded cable must be connected with earth terminal. The shielded cable must be connected with inner earth terminal directly inside the transducer, while the outside earth terminal on housing must be connected with ground. In the event of earth-connected current, the shielding side of shielded cable must be connected to ground potential via a ceramic capacitor (e.g. : 1 μ F 1500V) in order to dampen the low frequency grounding current and avoid the disturbance caused by high frequency signals

- Wiring Diagram

2-wire

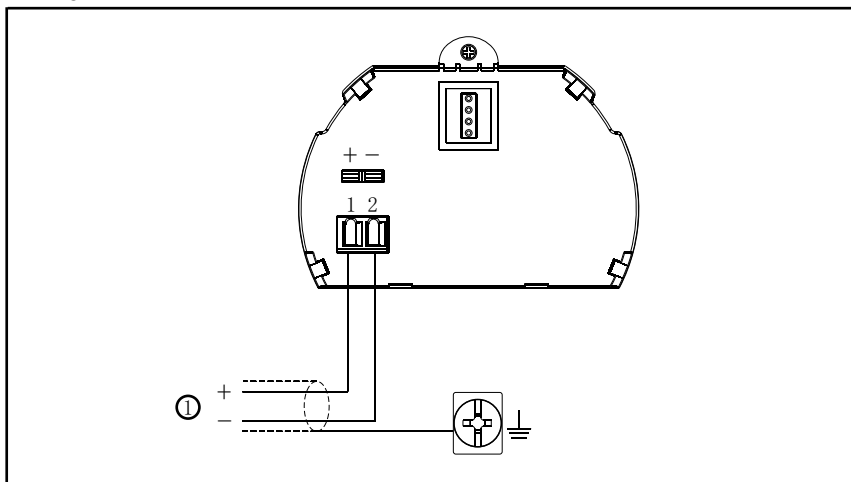

2-wire wiring used for HART
1) Power Supply and Signal Output

4-wire/2-chamber

Wiring Diagram: 200V AC Power Supply, 4...20mA Signal Output

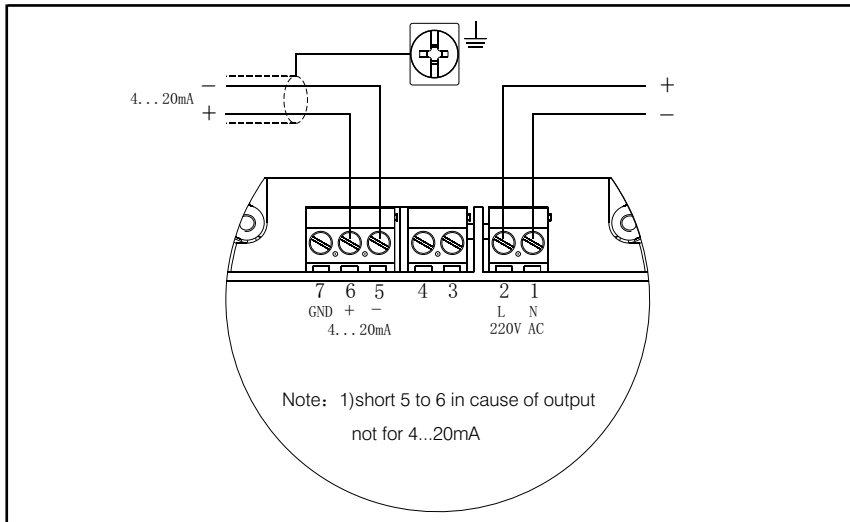

Wiring Diagram: 4-wire 24V DC Power Supply, 4...20mA Signal Output

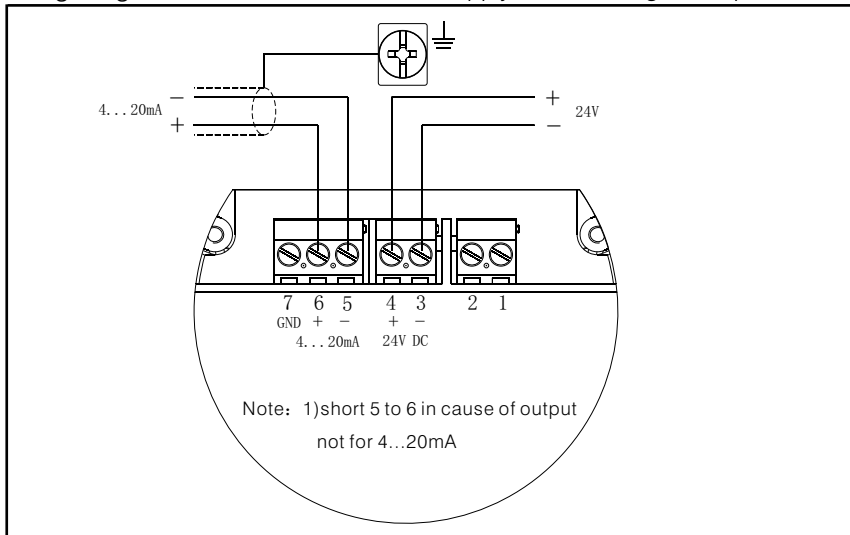

Wiring Diagram: dual-wire 24V DC Power Supply, 4...20mA Signal Output

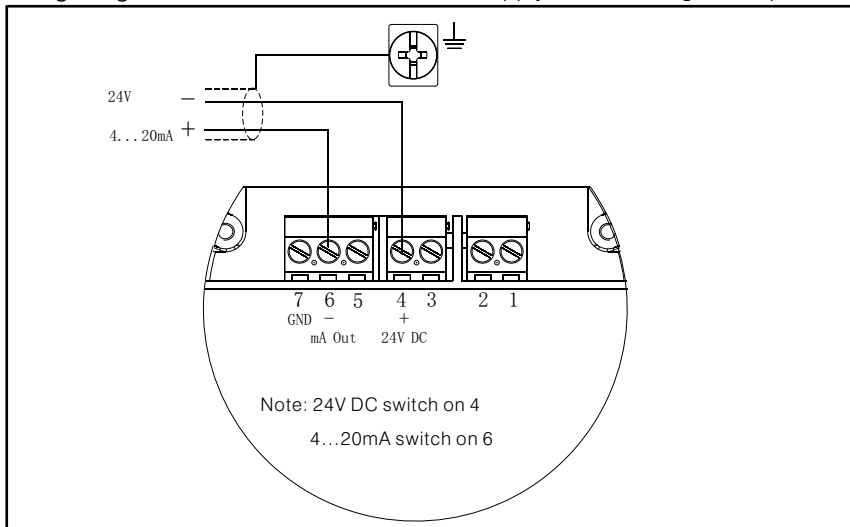

● Explosion Proof Connection

The intrinsic safety version sensors (Exia II c T6) use Alu-die casting housing and filling silicone rubber encapsulants internal structure aimed to prevent sparks resulted from circuit failure from leaking out. It is applicable for the continuous level measurement of flammable medium under Exia II c T6.

A safety barrier FBS-2 must be used together with the intrinsic safety instrument. It is an associated device to this product for the power supply of this product. The main specification is intrinsic safety: Exia II C, voltage of power supply: 24V DC±5%, short-circuit current: 135mA, operating current: 4...20mA.

All cables must be shielded. The max length is 500m for the cable from the barrier to the sensor. Stray capacitor $\leq 0.1 \mu\text{F/Km}$, stray inductance $\leq 1\text{mH/Km}$. Instrument must be connected to the ground potential. Any unapproved associated device is not allowed to be used.

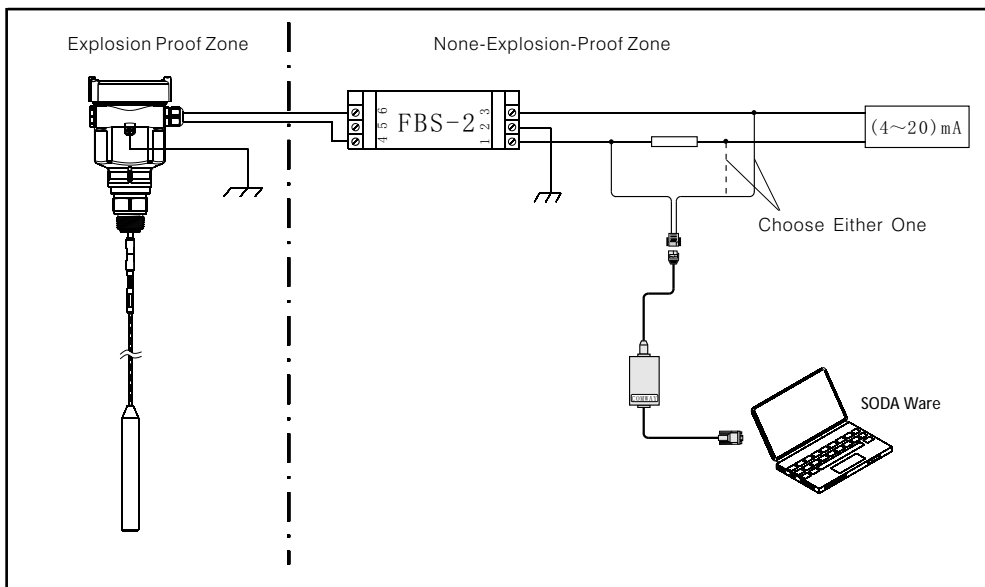

Adjustment with SODAWare

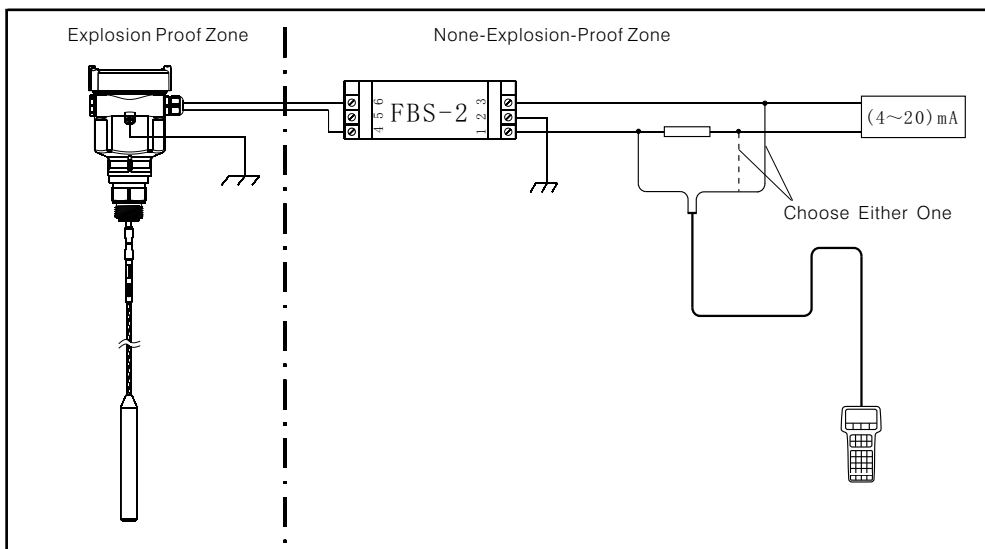

Adjustment with HART Handheld Programmer

5 Adjustment Instructions

● Adjustment Methods

Three methods are available for FDGW5X adjustment:

- 1 Display/adjustment module ViewPoint
- 2 An adjustment software- SODAware
- 3 HART handheld programmer

ViewPoint is a pluggable display/adjustment module. The adjustment can be done through operating with four buttons on ViewPoint. Optional menu operation languages are available for selection. ViewPoint is only used for display after adjustment in that the measurement results can be seen clearly through the glass window.

Display/Adjustment Module

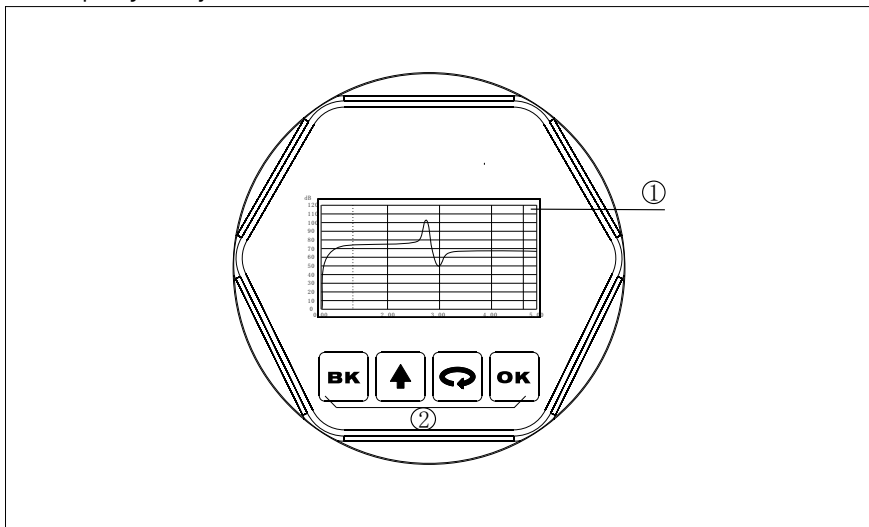

1 LCD 2 Adjustment Keypad

[OK] Keypad

- Enter programming mode;
- Confirm programming options;
- Confirm modifications to parameters.

[↻] Keypad

- Choose programming options;
- Choose the digit of parameters to edit;
- Display the contents of parameters.

[↑] Keypad

- Modify parameter values.

[BK] Keypad

- Programming mode exit;
- Return to higher menu level.

Shortcut

- [BK] Display Echo wave

SODAWare

Connect with another unit through HART.

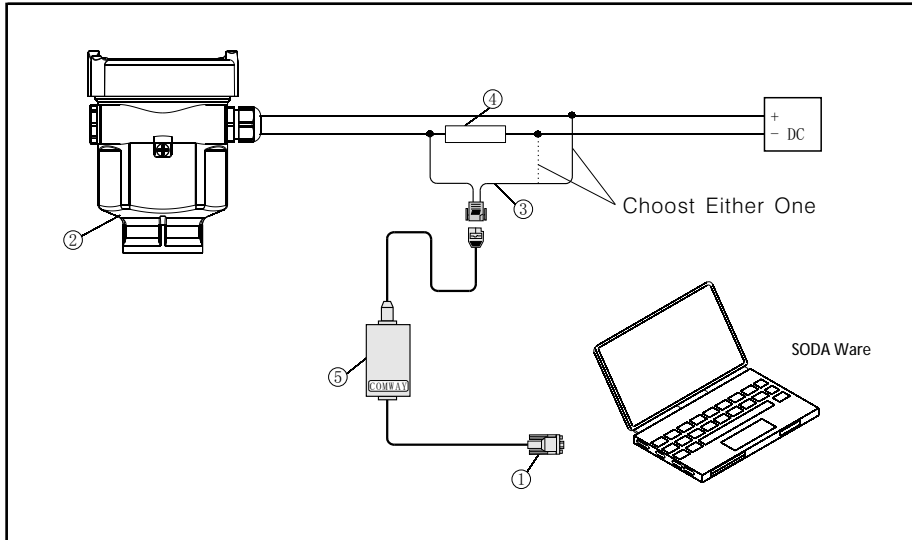

- 1 RS232 Connect Cable/USB port
- 2 FDRD5X
- 3 HATR pont adapter used on COMWAY convertor
- 4 250 ohm Resistance
- 5 COMWAY Convertor

S

Connect with another unit through I²C.

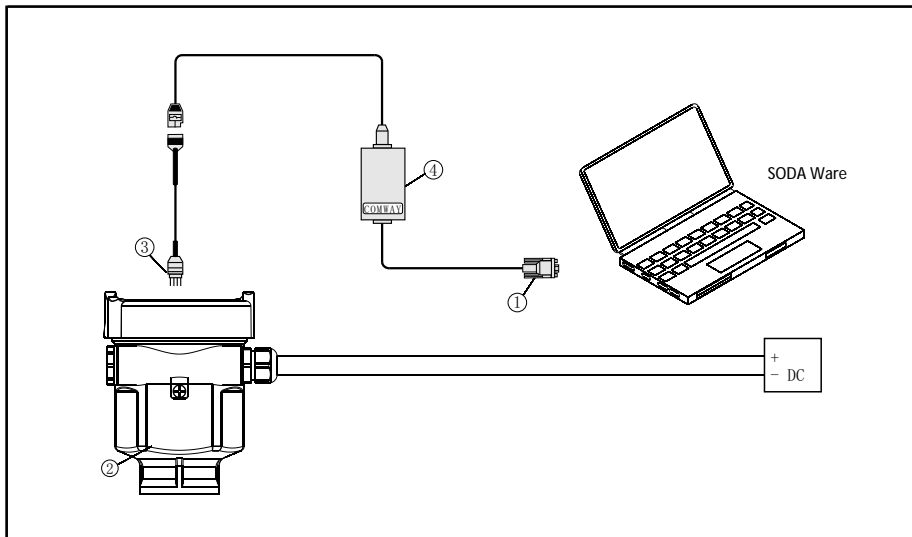

- 1 RS232 Connect Cable/USB port
- 2 FDRD5X
- 3 I²C adapter pont used on MOMWAY convertor
- 4 COMWAY Convertor

HART Handheld Programmer

Adjust FDRD5X with HART Handheld Programmer

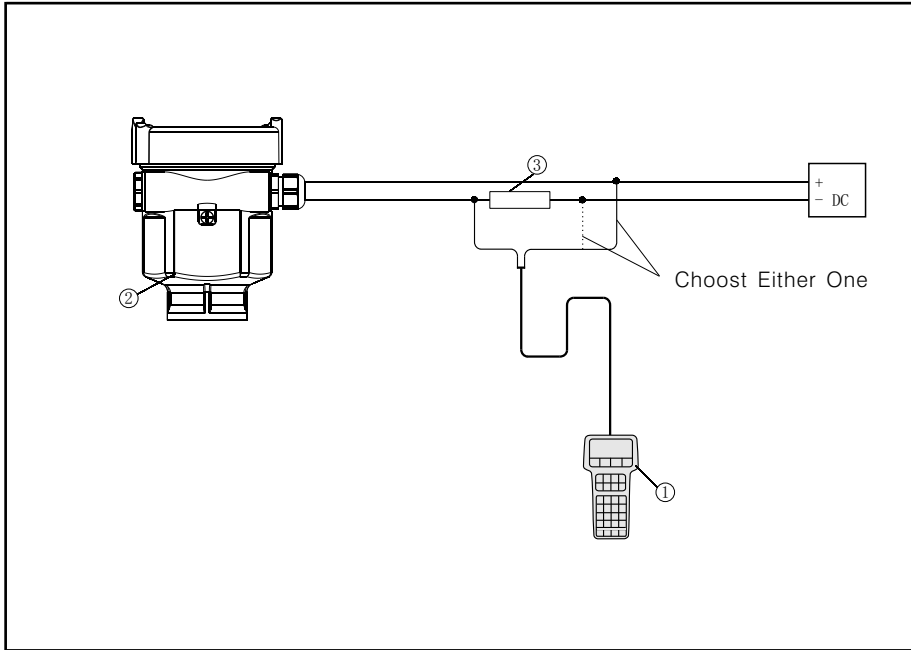

1 HART Handheld Programmer

2 FDRD5X

3 250 ohm Resistance

6 Dimension (Unit: mm)

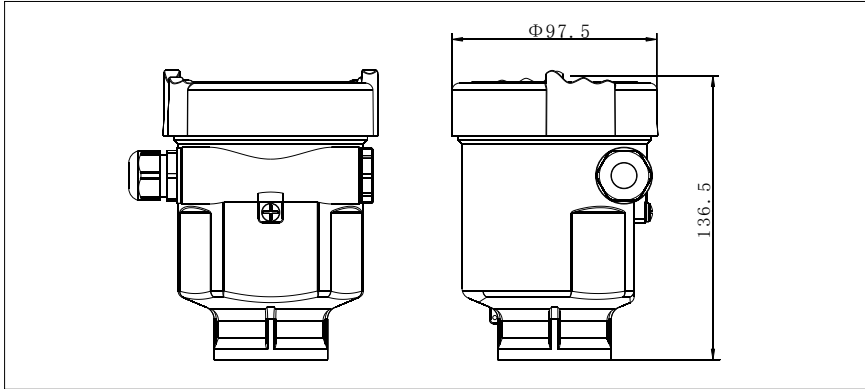

Housing
Material: PBT/AL/316L

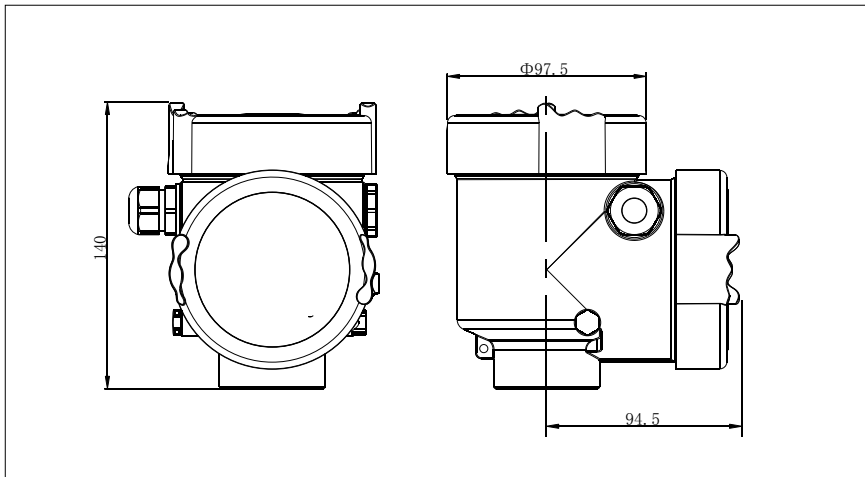

Material: two-chamber

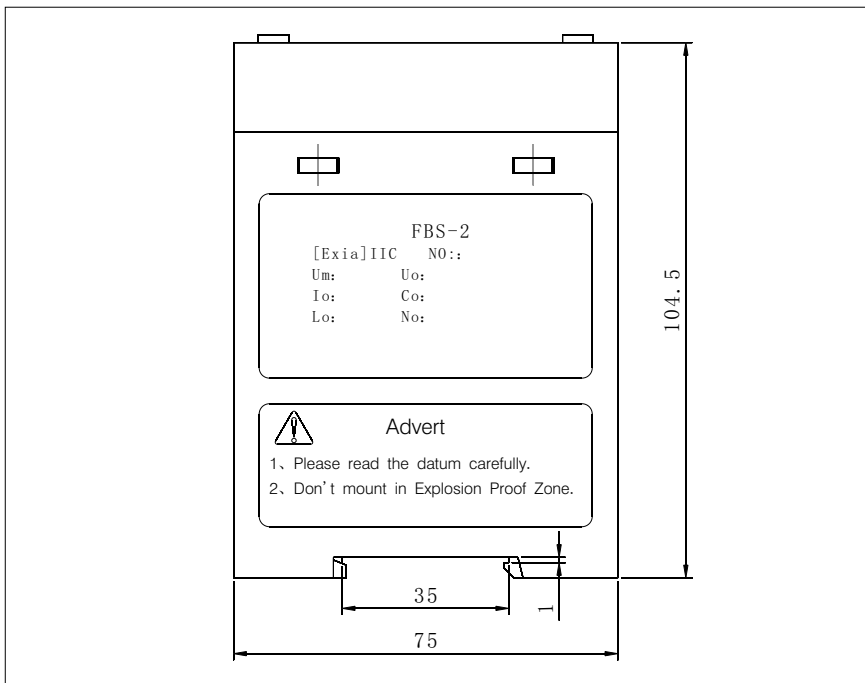

FBS Series

FDGW51

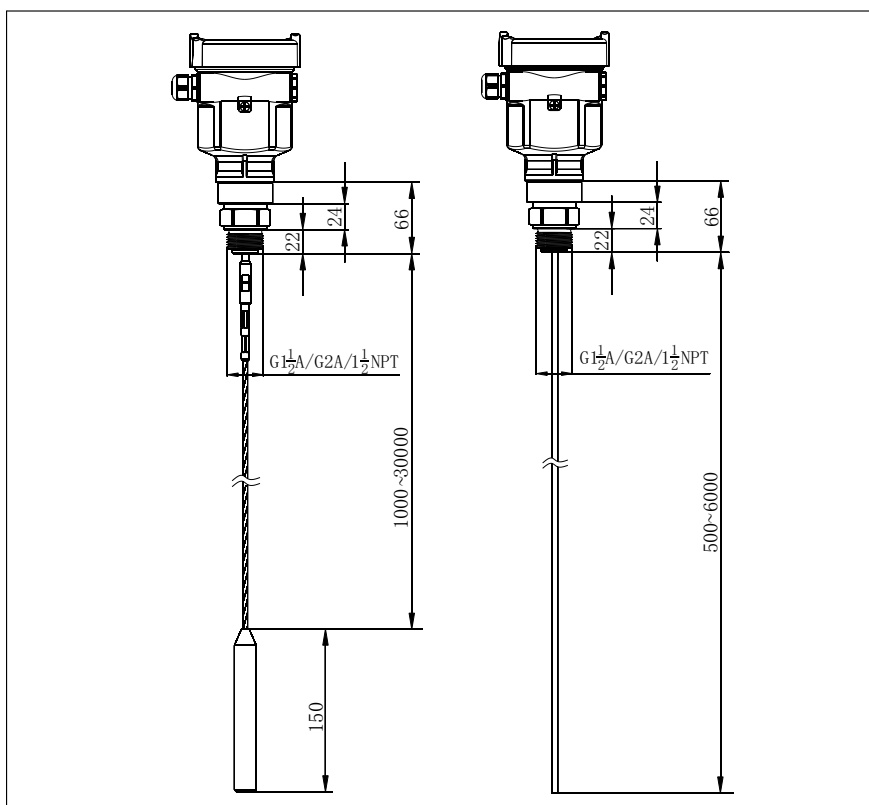

FDGW52

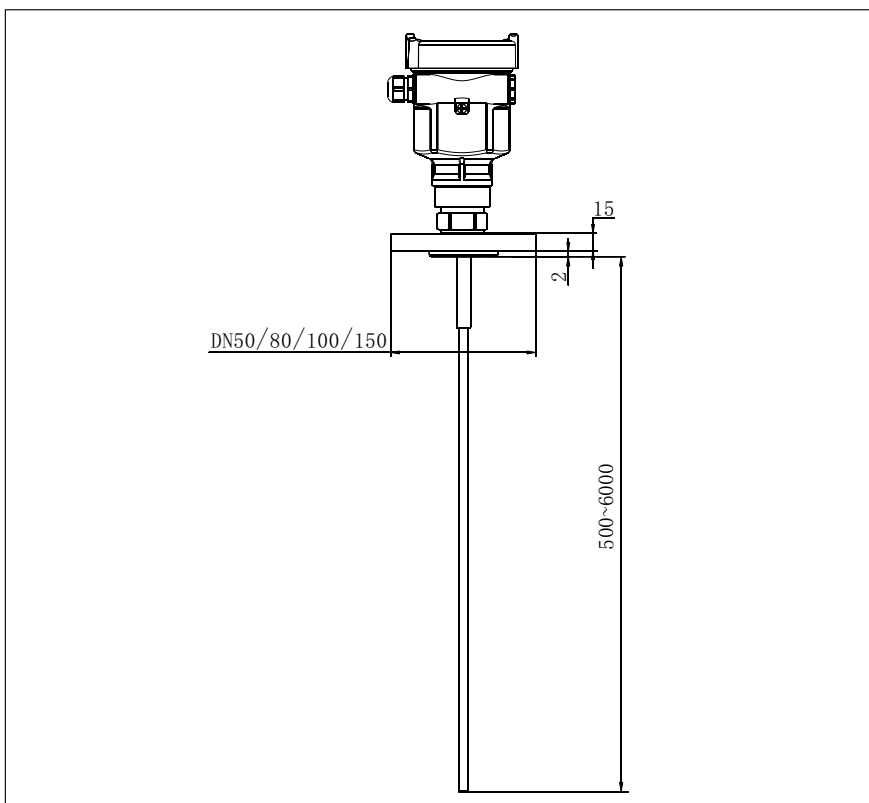

FDGW53

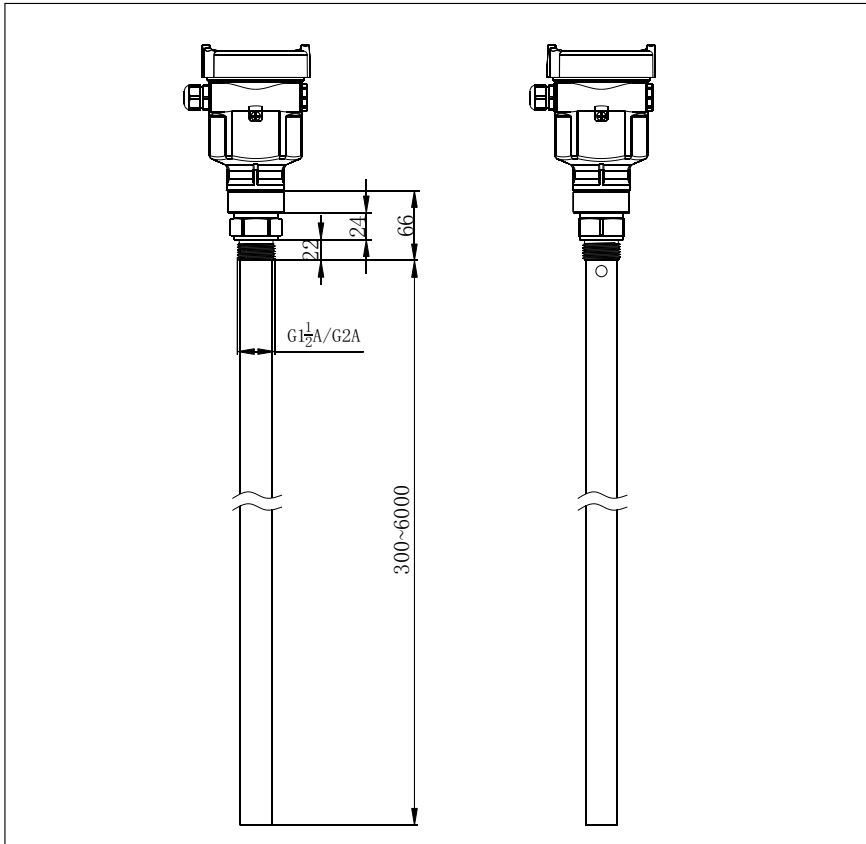

FDGW54

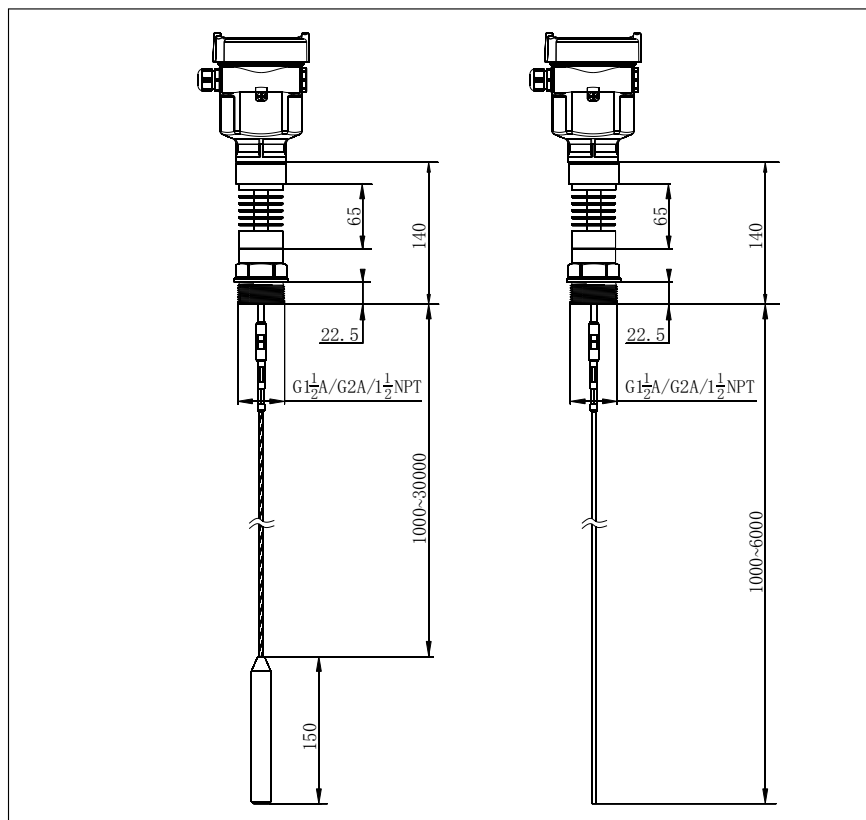

FDGW55

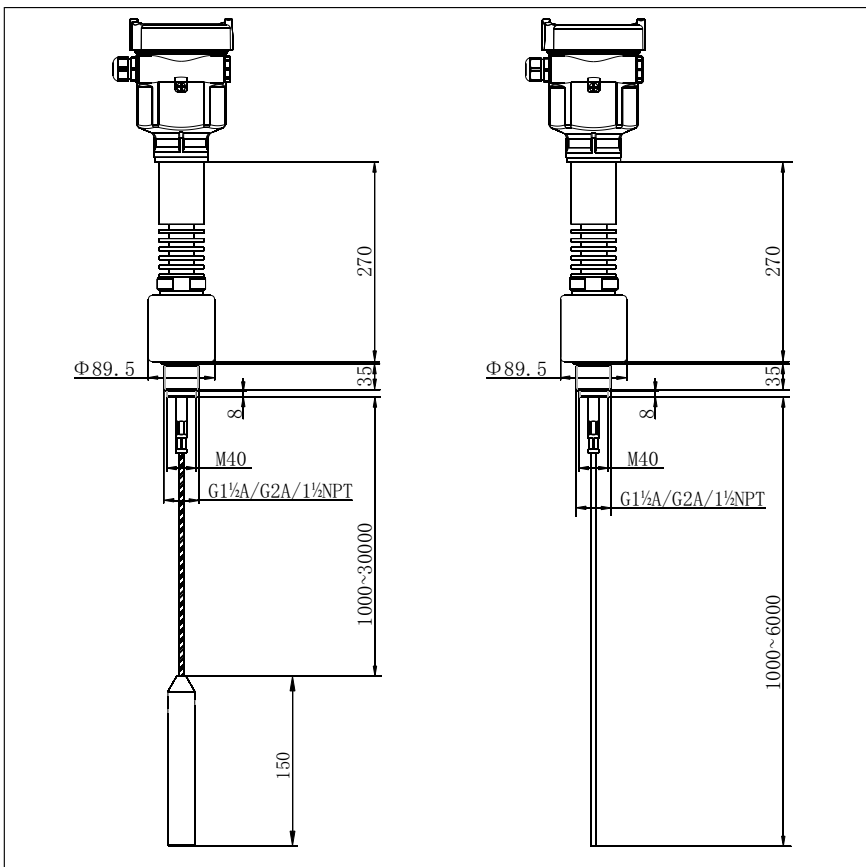

FDGW56

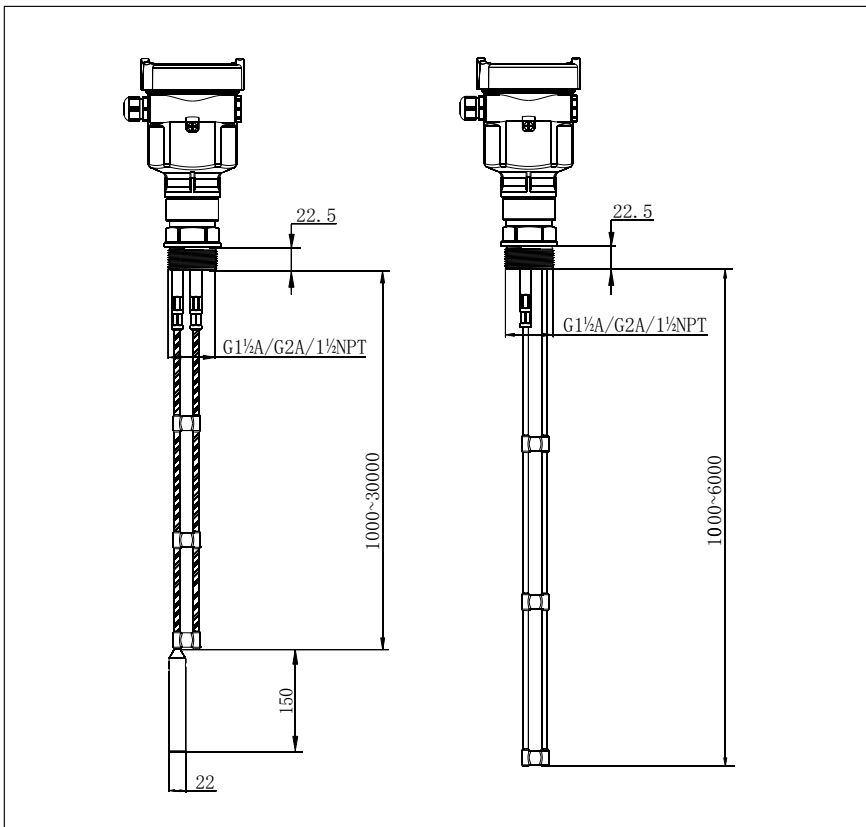

7 Technical Specifications

● General Parameters	Probe Material:	
	-Rod	Stainless Steel316L/PTFE
	-Cable	Stainless Steel316L/PTFE/ceramic
	-Coax	Stainless Steel316L/PTFE
	-Seal	Viton fluoroelastomer, Kalrez perfluoroelastomer
	-Process Connection	Stainless Steel316L
	-Housing	Stainless Steel316L Alu-die casting, Powder Coated,
	-Seal ring between housing and housing cover	Silicone rubber
	-ViewPoint window	Polycarbonate
	-Ground terminal	Stainless Steel316L
	Weight	
	-FDGW51	9kg (Depends on process connections and housing)
	-FDGW52	5.5kg (Depends on process connections and housing)
-FDGW53	6kg (Depends on process connections and housing)	
-FDGW54	12kg (Depends on process connections and housing)	
-FDGW55	9kg (Depends on process connections and housing)	
-FDGW56	9kg (Depends on process connections and housing)	
Power	2-Wire	
	-Standard Version	15...36V DC
	-Exia	15...30V DC
	Power consumption	max.22.5mA
	Ripple Allowed	
-<100Hz	U _{ss} <1V	
-<100Hz...10KHz		
4-wire/2-chamber		
-Ex dia version	24VDC±10%, 220VAC±10%	
Power Consumption	<1W	
Parameters on Cable	Cable Entry/Plug	One cable entry of M20X1.5 (cable diameter of 5...9mm), one blind stopper M20X1.5
	Spring Connection Terminal	Applicable for cables with cross section of 2.5mm
Output	Output Signal	4...20mA/HART
	Resolution	1.6µA
	Failure mode	20.5mA, 22mA, hold
	-2-wire load resistance	See the diagram below
	-4-wire load resistance	Max.500ohm
	Integration Time	0...40sec, adjustable

2-Wire Load Resistance Diagram

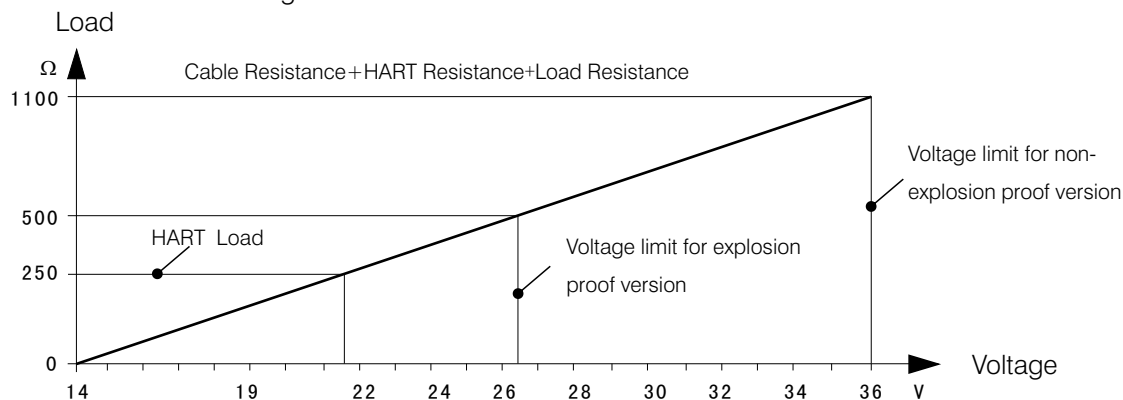

Technical data

Max Measurement Distance	
- FDGW51	30m/6m (Rope/Rod)
- FDGW52	6m
- FDGW53	6m
- FDGW54	30m/6m
- FDGW55	30m/6m
- FDGW56	30m/6m
Measurement Interval	About 1sec (Depend on parameter settings)
Adjustment Time ¹⁾	About 1sec (Depend on parameter settings)
Resolution of Display	1mm
Accuracy	See the accuracy illustration diagram below

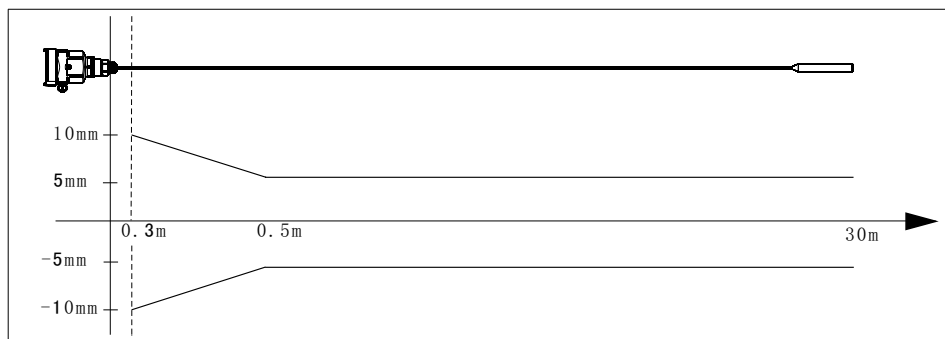

Temperature for Storage/Transport	-40...+80°C
Process Temperature (Probe)	
- FDGW51, FDGW52, FDGW53, FDGW56	-40...+150°C
- FDGW54	-40...+200°C
- FDGW55	-200...+400°C
-Relative Humidity	<95%
-Pressure	Max.400bar
Vibration Proof	Mechanical vibration 10m/s ² , 10...150Hz
Max Pulling Force	See the illustrative diagram on pulling force
Max Pulling Force or Lateral Load	

¹⁾ The generation of accurate measurement results needs longer time than usual in the event of drastic level changes(mx. Error 10%).

When measuring solid medium, the pulling force is determined by the diameter of vessel and medium level, some examples of pulling force generated by typical medium are shown on the diagrams below.

FDGW51

Metal vessle with smooth sidewall
 - - - - - Diameter: 12m
 - . - . - Diameter: 9m
 - - - - - Diameter: 6m
 ——— Diameter: 3m

Grain

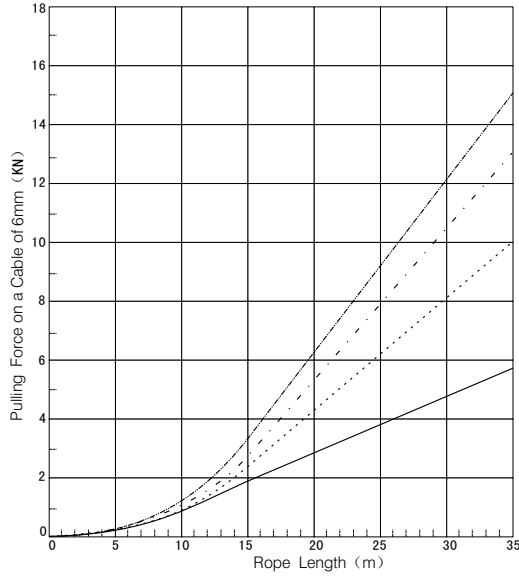

Sand

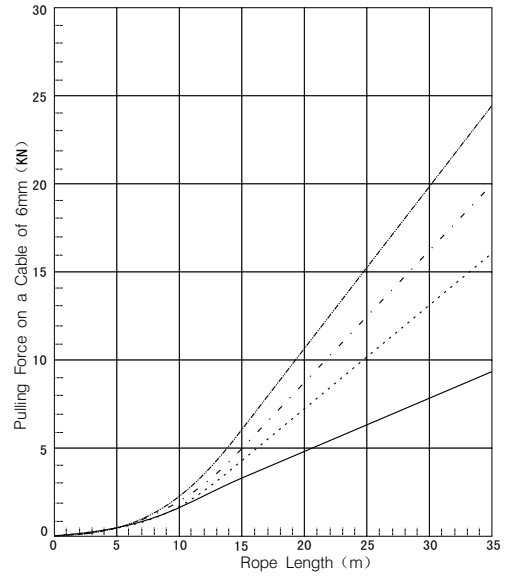

Plastic Particle

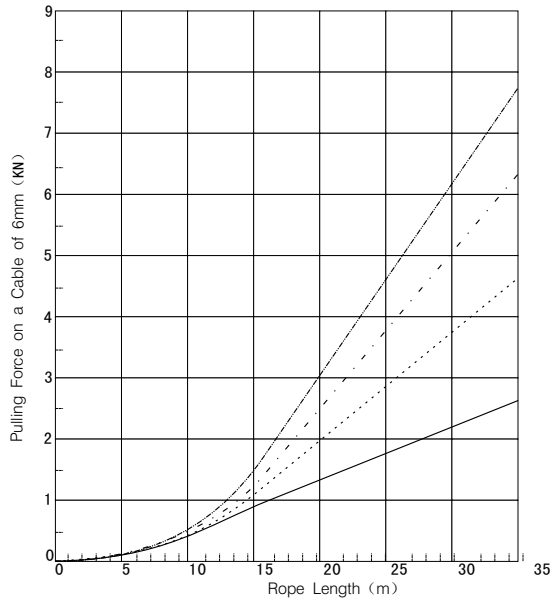

Cement

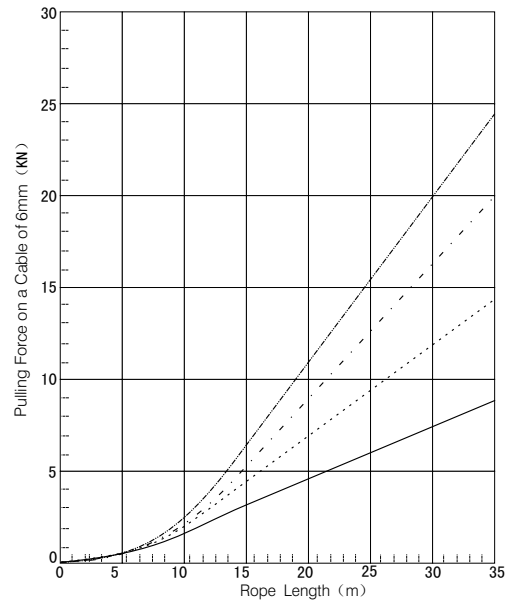

8 Selection & Ordering Information

● FDGW51

Explosion Proof Approval	
P	Standard (Without Approval)
I	Intrinsically Safe (Exia IIC T6)
C	Intrinsically Safe+Ship Approval (Exia IIC T6)
G	Intrinsically Safe+Explosion proof (Exd ia IIC T6)
Type of detecting component/Material	
A	Rope/Φ6mm/Stainless Steel316L/PTFE
B	Rope/Φ10mm/Stainless Steel316L/PTFE
C	Lengthen PP/Rope/Stainless Steel 316L
D	Lengthen PP/Rod/Stainless Steel 316L
E	Lengthen PTFE/Rope/Stainless Steel 316L
F	Lengthen PTFE/Rod/Stainless Steel 316L
X	Special Design
Seal/Process Temperature	
GP	Thread G1½A
KP	Thread G2A
NP	Thread 1½NPT
YP	Special Design
Seal/Process Temperature	
A	Viton / (-30~150) °C
B	Kalrez/ (-40~150)°C
Electronic	
B	(4~20)mA/HART 2-wire
C	(4~20)mA/(22.8~26.4)V DC /HART 2-wire/4-wire
D	(198~242)V AC/HART 4-wire
Housing/Protection	
A	Aluminium/IP67
B	Plastic/IP66
D	Aluminium (2-chamber)/IP67
G	Stainless Steel316L/IP66
Cable Entry	
M	M20x1.5
N	½NPT
Display/Programming	
A	Yes
X	No
Rope/rod length	
5-digit number (unit:mm)	

Note: The instrument with approval I can only use Electronic A or B and housing A, The instrument with approval C can only use Electronic A or B and housing G, The instrument with approval G can only use Electronic C or D and housing D.

●FDGW52

Explosion Proof Approval	
P	Standard (Without Approval)
I	Intrinsically Safe (Exia IIC T6)
C	Intrinsically Safe+Ship Approval (Exia IIC T6)
G	Intrinsically Safe+Explosion proof (Exd ia IIC T6)
Type of detecting component/Material	
A	Rod/Φ6mm/Stainless Steel 316L
Process Connection/Material	
GP	flange DN50 PN1.6 Stainless Steel 316L (GB/T9119-2000)
NP	flange DN80 PN1.6 Stainless Steel 316L (GB/T9119-2000)
EP	flange DN100 PN1.6 Stainless Steel 316L (GB/T9119-2000)
FP	flange DN150 PN1.6 Stainless Steel 316L (GB/T9119-2000)
YP	Special Design
Seal/Process Temperature	
A	(-40~150) °C
Electronic	
B	(4~20)mA/HART 2-wire
C	(4~20)mA/(22.8~26.4)V DC /HART 2-wire/4-wire
D	(198~242)V AC/HART 4-wire
Housing/Protection	
A	Aluminium/IP67
B	Plastic/IP67
D	Aluminium (2-chamber)/IP67
G	Stainless Steel316L/IP67
Cable Entry	
M	M20x1.5
N	½NPT
Display/Programming	
A	Yes
X	No
Rope/rod length	
5-digit number (unit:mm)	

Note: The instrument with approval I can only use Electronic A or B and housing A, The instrument with approval C can only use Electronic A or B and housing G, The instrument with approval G can only use Electronic C or D and housing D.

● FDGW53

Explosion Proof Approval	
P	Standard (Without Approval)
I	Intrinsically Safe (Exia IIC T6)
C	Intrinsically Safe+Ship Approval (Exia IIC T6)
G	Intrinsically Safe+Explosion proof (Exd ia IIC T6)
Type of detecting compencent/Material	
A	Coax/Stainless Steel316L
Process Connection/Material	
GP	Thread G1½A
KP	Thread G2A
NP	Thread 1½NPT
YP	Special Design
Seal/Process Temperature	
A	Viton/ (-30~150)°C
B	Kalrez/ (-40~150) °C
Electronic	
B	(4~20)mA/HART 2-wire
C	(4~20)mA/(22.8~26.4)V DC /HART2-wire/4-wire
D	(198~242)V AC/HART 4-wire
Housing/Protection	
A	Aluminium/IP67
B	Plastic/IP67
D	Aluminium (2-chamber)/IP67
G	Stainless Steel316L/IP67
Cable Entry	
M	M20x1.5
N	½NPT
Display/Programming	
A	Yes
X	No
Rope/rod length	
5-digit number (unit:mm)	

Note: The instrument with approval I can only use Electronic A or B and housing A, The instrument with approval C can only use Electronic A or B and housing G, The instrument with approval G can only use Electronic C or D and housing D.

● FDGW54

Explosion Proof Approval	
P	Standard (Without Approval)
I	Intrinsically Safe (Exia IIC T6)
C	Intrinsically Safe+Ship Approval (Exia IIC T6)
G	Intrinsically Safe+Explosion proof (Exd ia IIC T6)
Type of detecting component/Material/Process Temperature	
A	Rope/Stainless Steel 316L/PTFE
B	Rod/Stainless Steel 316L/PTFE
C	Lengthen PP/Rope/Stainless Steel 316L
D	Lengthen PP/Rod/Stainless Steel 316L
E	Lengthen PTFE/Rope/Stainless Steel 316L
F	Lengthen PTFE/Rod/Stainless Steel 316L
X	Special Design
Process Connection/Material	
GP	Thread G1½A
KP	Thread G2A
NP	Thread 1½NPT
YP	Special Design
Seal/Process Temperature	
A	Viton/ (-30~150)°C
B	Kalrez/ (-40~150) °C
Electronic	
B	(4~20)mA/HART 2-wire
C	(4~20)mA/(22.8~26.4)V DC /HART2-wire/4-wire
D	(198~242)V AC/HART 4-wire
Housing/Protection	
A	Aluminium/IP67
B	Plastic/IP67
D	Aluminium (2-chamber)/IP67
G	Stainless Steel316L/IP67
Cable Entry	
M	M20x1.5
N	½NPT
Display/Programming	
A	Yes
X	No
Rope/rod length	
5-digit number (unit:mm)	

Note: The instrument with approval I can only use Electronic A or B and housing A, The instrument with approval C can only use Electronic A or B and housing G, The instrument with approval G can only use Electronic C or D and housing D.

● FDGW55

Explosion Proof Approval	
P	Standard (Without Approval)
I	Intrinsically Safe (Exia IIC T6)
C	Intrinsically Safe+Ship Approval (Exia IIC T6)
G	Intrinsically Safe+Explosion proof (Exd ia IIC T6)
Type of detecting component/Material	
A	Rope/Stainless Steel316L/Ceramic
B	Rod/Stainless Steel316L/Ceramic
Process Connection/Material	
GP	Thread G1½A
KP	Thread G2A
NP	Thread 1½NPT
YP	Special Design
Electronic	
B	(4~20) mA/HART 2-wire
C	(4~20) mA/(22.8~26.4) V DC /HART2-wire/4-wire
D	(198~242) V AC/HART 4-wire
Housing/Protection	
A	Aluminium/IP67
B	Plastic/IP67
D	Aluminium (2-chamber)/IP67
G	Stainless Steel316L/IP67
Process Temperature	
A	(-200~400) °C/ (Vacuum~4) MPa
B	(-200~400) °C/ (Vacuum~40) MPa
Cable Entry	
M	M20x1.5
N	½NPT
Display/Programming	
A	Yes
X	No
Rope/rod length	
5-digit number (unit:mm)	

Note: The instrument with approval I can only use Electronic A or B and housing A, The instrument with approval C can only use Electronic A or B and housing G, The instrument with approval G can only use Electronic C or D and housing D.

● FDGW56

Explosion Proof Approval	
P	Standard (Without Approval)
I	Intrinsically Safe (Exia IIC T6)
C	Intrinsically Safe+Ship Approval (Exia IIC T6)
G	Intrinsically Safe+Explosion proof (Exd ia IIC T6)
Type of detecting component/Material	
A	Rope/Stainless Steel 316L/PTFE
B	Rod/Stainless Steel 316L/PTFE
Process Connection/Material	
GP	Thread G1½A
KP	Thread G2A
NP	Thread 1½NPT
YP	Special Design
Electronic	
B	(4~20)mA/HART 2-wire
C	(4~20)mA/(22.8~26.4)V DC /HART2-wire/4-wire
D	(198~242)V AC/HART 4-wire
Housing/Protection	
A	Aluminium/IP67
B	Plastic/IP67
D	Aluminium (2-chamber)/IP67
G	Stainless Steel316L/IP67
Process Temperature	
A	(-200~400) °C/ (Vacuum~4) MPa
B	(-200~400) °C/ (Vacuum~40) MPa
Cable Entry	
M	M20x1.5
N	½NPT
Display/Programming	
A	Yes
X	No
Rope/rod length	
5-digit number (unit:mm)	

Note: The instrument with approval I can only use Electronic A or B and housing A, The instrument with approval C can only use Electronic A or B and housing G, The instrument with approval G can only use Electronic C or D and housing D. 标配法兰大小参照GB/T9119-2000 PN1.6MPa尺寸,厚度为15.

9 Application Questionnaire

Approvals

- Standard Version Intrinsically Safe Version (Exia IIC T6) Intrinsically Safe Version (Exia IIC T6)
 Intrinsically Safe Version+Ship Approval (Exia IIC T6) Intrinsically Safe Version+Explosion Proof (Exd [ia] IIC T6)

Measured Medium

Name _____

Condition Liquid (Solid (Form Mass Particle Dust)

Temperature: Min. _____ °C Norm. _____ °C Max. _____ °C

Surface Flat Turbulent Agitated Vortex

Dielectric Constant $\epsilon_r < 3$ $\epsilon_r > 3$

Atmosphere

Atmosphere Form Foam Dust Deposit Vapour

Atmosphere Pressure Min. _____ Norm. _____ Max. _____

Vessel

Shape of Top Flat Arch Conical Horizontal

Height _____ Diameter _____

Critical Information

Nozzle Length: _____ Nozzle Diameter: _____ Measurement Range: _____

Process Connection

Thread (G $\frac{1}{2}$ A $\frac{1}{2}$ NPT G1A G1A, M105x2 G1 $\frac{1}{2}$ A 1 $\frac{1}{2}$ NPT G2A)

Flange (DN=) Swivelling Holder

Installation

Mode: Top Side

Filling Stream inlet position and installation position (Please specify in the diagram below)

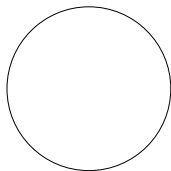

Circular Vessel



Square Vessel

Power Supply

220V AC 2-wire 24V DC 3-wire 24V DC 4-wire 24V DC

Communication

(4~20) mA/HART

Display

Yes No

Customer Information

Contact: _____

Company: _____

Address: _____

P. C.: _____ Tel: _____

Email: _____ Fax: _____

Please give brief explanation on the application of instrument:

Date: _____